

STI-94

- ratemeter to control rotational speed
- 1 pulse counting input
- 2 or 4 relay outputs (or OC)
- RS-485 / Modbus RTU
- option: active current output



STI-94 ratemeters are the board-type ratemeters designed to control rotational speed. Available parameters of divider and multiplier enable flexible scaling of rotational speed and also transformation into material linear speed. On top of that, they enable operation in the frequency meter mode. The ratemeters have 2 or 4 relay or OC outputs, programmable depending on the instantaneous rotational speed.

- password protection,
- "over" signalling when the measuring range is exceeded,
- setting the rotational speed units,
- settable delay time of relay: up to 99 seconds or minutes,
- settable maximum waiting time for the next rotation,
- threshold hysteresis setting,
- ACCESS option - easy threshold modification,
- versions available with AC and DC power supply.

Typical applications

1. Measuring the speed of the material being wound, featuring alarm signalling and drive system control.

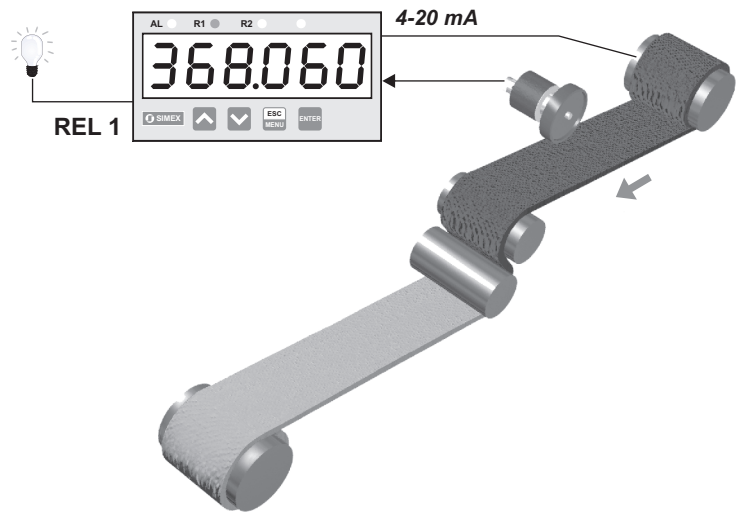

Exemplary pin assignment

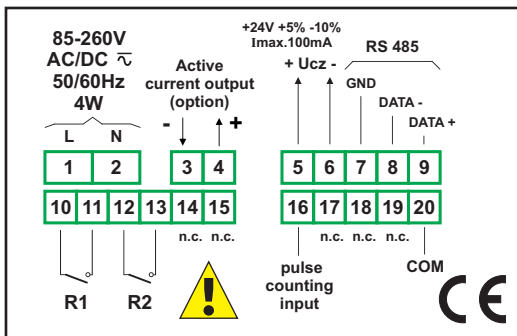

version with 4-20 mA output and two relays

Technical data

- Power supply:** 19V + 50V DC; 16V + 35V AC or 85 + 260V AC/DC
- Power consumption:** for 85 + 260V AC/DC and 16V + 35V AC power supply: max. 4,5 VA; 19V + 50V DC power supply: max. 4,5 W
- Display:** LED, red, 6 x 13 mm high
- Inputs:** pulse, galvanically isolated without contacts oscillation damping
maximum input frequency: 50 kHz
maximum frequency behind the pulse divider: 500 Hz
- Rotational speed accuracy:** selected in the 0 + 0,000 range
- Rotational speed unit:** rpm or revolutions per second
- Pulse waiting time:** settable from 0,1 to 39,9 seconds
- Measuring range:** 0 + 999999 + decimal point
- Outputs:** 2 or 4; relays 1A/250V AC (cos =1) or the OC 30mA/30VDC/ /100mW
- Transducer power supply output:** 24V DC +5% -10% / max. 100 mA, stabilized, not insulated from measuring inputs
- Active current output:** operating range max. 0 - 24 mA (option available with 2 relays, see ordering)
- Communication interface:** RS 485, 8N1, 2400 bit/s + 115200 bit/s, Modbus RTU (not galvanically isolated)
- Data memory:** non-volatile memory, EEPROM type
- Operating temperature:** 0°C + +50°C
- Storage temperature:** -10°C + +70°C
- Protection class:** IP 65 (front side when an additional frame is installed); IP 40 (front side); IP 20 (case and connection clips)
- Case:** board
- Case material:** NORYL - GFN2S E1
- Case dimensions:** 96 x 48 x 100 mm
- Panel cut-out dimensions:** 90,5 x 43 mm
- Installation depth:** min. 102 mm
- Board thickness:** max. 5 mm

Ordering

STI-94-14XX-1-X-XX1

- options:**
- 00 : no options
- 01 : IP65
- power supply:**
- 3 : 24V AC/DC
- 4 : 85V - 260V AC/DC
- number of outputs:**
- 2
- 3
- 4
- type of outputs:**
- 1 : REL (for 2 and 4 outputs)
- 2 : OC (for 2 and 4 outputs)
- 3 : 2 x REL + current output
- 4 : 2 x OC + current output