

## INTRODUCTION

**Logbox-AA** is a dual channel universal input data logger which directly accepts several analog industrial signals and sensors as voltage, current, thermocouples and RTDs.

This self-operated logger is extremely flexible and can be easily programmed and set via a handy infrared **IR-LINK 3** interface connected to a USB port under Windows software or with a Palm compatible PDA IrDA interface under PalmOS.

**LogChart II** software allows for logger configuration, recorded data retrieval, plotting and historical analysis and exports data to spread sheets.

Its sturdy water proof enclosure provides full performance in the most demanding applications.



## CONFIGURATION

**LogChart II** software allows for logger configuration, recorded data retrieval, plotting and historical analysis and exports data to spread sheets.

Infrared communication to a PC is achieved by using the **IrLink 3** interface connected to a USB port (RS232 is optional).

Configuration, data retrieval and analysis can be also done by using a convenient Palm OS compatible PDA through its **IrDA** interface. This reduces cost and dramatically increases portability.

Data downloaded from multiple **LogBox** units to a Palm can be later transferred and synchronized to a PC by means of the native Palm sync tool.

Once the data are transferred to a PC they can then be better visualized and exported by the **LogChart II** software.

## SPECIFICATIONS

- Dual universal multi-sensor inputs, individually programmable for Pt100, Thermocouples (types J, K, T, E, N, R, S or B), voltage (0 to 50 mV or 0 to 10 V), or current (0 to 20 mA or 4 to 20 mA).
- Accuracy: 0.2% of full scale for Pt100, current and voltage; 0.25% of full scale  $\pm 3^{\circ}\text{C}$  for  $t/c$ s type R,S and B; 0.25% of full scale  $\pm 1^{\circ}\text{C}$  for all other thermocouples.
- Input resolution: 14 bits.
- Launch options: immediate, programmed time and date, or via Palm;
- Stop options: when full, at a certain time, after a number of readings, or wrap around (overwrites first readings).
- Internal button and external signal input for **stop/go**.
- Data acquisitions can be repeated daily;
- Memory for 32,000 recordings in one channel or 16,000 recordings for each channel;
- Infrared communication up to 1 meter away;
- Recording interval: programmable from 1 s to 18 hours;
- Built in real time clock;
- Internal replaceable lithium cell (3.6V  $\frac{1}{2}$  AA);
- Estimated battery life: 1 year with one daily download and 5 min measuring interval. Battery life depends heavily on data retrieval frequency;
- Switching circuit for powering remote transducers (only in IP65 version).
- Configuration and data retrieval software for Windows 98, XP, 2000 and PalmOS;
- Operating temperature:  $-40^{\circ}\text{C}$  to  $70^{\circ}\text{C}$ .
- IP65 housing. Optional: IP67 or IP68.
- Dimensions: 70 x 60 x 35 mm.



## SENSOR TYPES AND RANGES

TYPE	CHARACTERISTICS
• Thermocouple K	-90 to 1370°C
• Thermocouple J	-50 to 760°C
• Thermocouple R	0 to 1760°C
• Thermocouple S	0 to 1760°C
• Thermocouple T	-100 to 400°C
• Thermocouple N	-90 to 1300°C
• Thermocouple E	-40 to 720°C
• Thermocouple B	150 to 1820°C
• Pt100	-200.0 to 650.0°C
• 0-10 V	Programmable Indic. -32768 to 32767
• 0-50 mV	Programmable Indic. -32768 to 32767
• 4-20 mV	Programmable Indic. -32768 to 32767

DATA ANALYSIS

CONFIGURATION

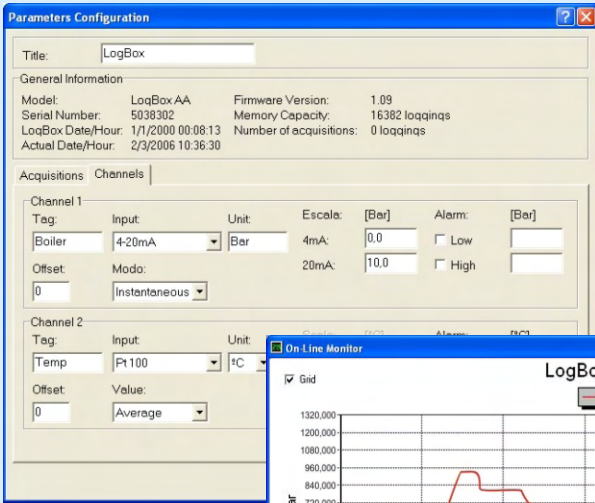

TABLE

Record Nr.	Time	Date	Boiler [Bar]	Temp [°C]
02852	18:53:51	2/3/2006	10,6	69,3
02853	18:54:01	2/3/2006	10,6	69,2
02854	18:54:11	2/3/2006	10,6	69,2
02855	18:54:21	2/3/2006	10,6	69,2
02856	18:54:31	2/3/2006	10,6	69,2
02857	18:54:41	2/3/2006	10,6	69,2
02858	18:54:51	2/3/2006	10,6	69,2
02859	18:55:01	2/3/2006	10,6	69,2
02860	18:55:11	2/3/2006	10,6	69,2
02861	18:55:21	2/3/2006	10,6	69,2
02862	18:55:31	2/3/2006	10,6	69,2
02863	18:55:41	2/3/2006	10,6	69,2
02864	18:55:51	2/3/2006	10,6	69,2
02865	18:56:01	2/3/2006	10,6	69,2
02866	18:56:11	2/3/2006	10,6	69,2
02867	18:56:21	2/3/2006	10,6	69,3
02868	18:56:31	2/3/2006	10,6	69,3
02869	18:56:41	2/3/2006	10,6	69,2
02870	18:56:51	2/3/2006	10,6	69,2
02871	18:57:01	2/3/2006	10,6	69,2
02872	18:57:11	2/3/2006	10,6	69,2

GRAPHIC

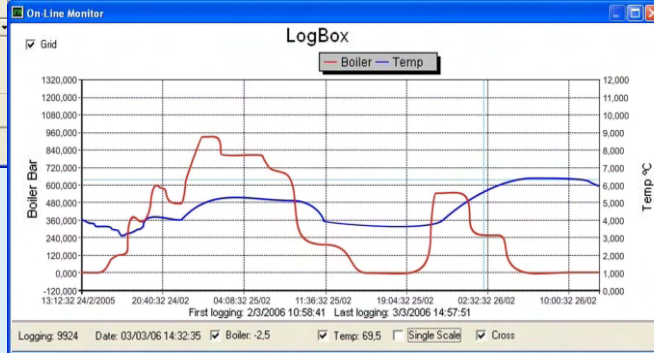

ELECTRICAL CONNECTIONS

Standard Version

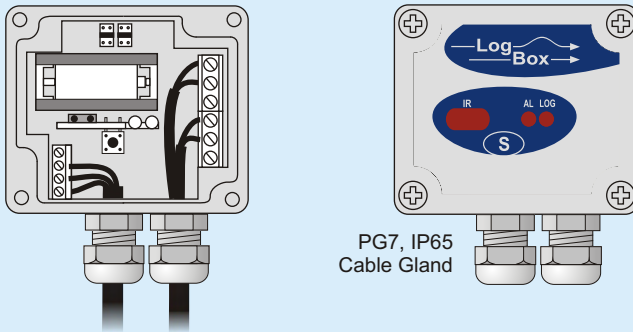

PG7, IP65 Cable Gland

IP67 Version

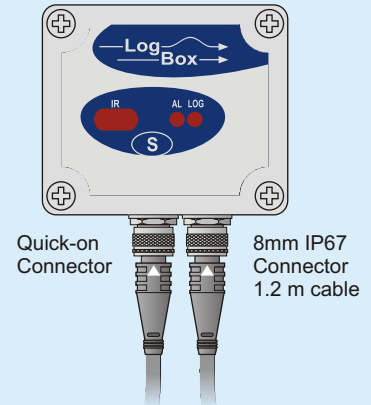

Quick-on Connector

8mm IP67 Connector 1.2 m cable

DIMENSIONS

